

T66N / 110N Stand-on tow tractor

Rated capacity: 6600lbs /11000lbs

T66N/110N is a stand-on tow tractor equipped with German three-phase AC drive motor and Italian ZAPI controller which ensures strong power and smooth acceleration and deceleration. Electric Power Steering(EPS) and German REMA handle ensures high efficiency and provides excellent driving experience.

4-point structure with floating platform and rubber pad helps to minimize vibration. Automotive grade curved backrest can reduce worker's fatigue greatly. Side extraction allows for fast replacement of battery so as to fulfill the needs of multi shifts.

Other options available include extension bracket, warning light, blue spot light, electric coupling, big storage tray, double USB charging ports, storage tray etc. which helps to make your work easier and more efficient.



7719 Edison Ave
Fontana, Ca 92336



info@esslifts.com



833-377-5438



www.esslifts.com

ESS LIFTS



Official Website

NEW *Noblelift Products*
ARRIVAL

ESS LIFTS - AN AUTHORIZED DEALER

www.esslifts.com

Safe and comfortable, easy storage



The standard blue light is not only automatically activated when the truck is driving forward, but also turns simultaneously with the handle while steering, which will increase the safety of operation.



Large storage tray can be used for storing stretch film, art knife, marker pen, or other tools.



Double storage tray can separate storage tools or garbage, makes work more efficient.



Safety flanks and non-slip surface materials on both sides of the backrest ensure the operator not to be thrown off while the truck turns at high speed. This design greatly improves the safety of driving. Meanwhile, the handle above the backrest provides a grasping point for the operator while getting on/off the truck, provides superior comfort for the operator.

T66N

- Rated capacity: 6600lbs
- Rated pulling capacity: 800N
- Travel speed (laden/unladen): 3.7/5.6mph
- Drive unit: 1.9kW
- Standard 24V375Ah lead acid battery
- Wheels' number 1x+2(x=driven wheels)

Robust and durable structure, high power and efficient driving technology



Italian Zapi controller

The Italian Zapi drive controller provides clients with reliable, flexible and high-performance control system solution.



German drive wheel tyre delivers much longer service life with high loading capacity and extraordinary abrasive resistance.



German AC drive technology

AC drive system performs perfectly thanks to the powerful Schabmüller maintenance free AC motor and Kordel gearbox imported from Germany, regardless of smooth or fast acceleration.

Other optional parts



A variety of expansion brackets can be selected to meet the installation requirements of different expansion equipment, such as: WMS display, barcode scanner, storage box, folder board, etc.



Steering light, brake light and parking light make driving safer.



The reinforced couplers can be set at three different heights so as to ensure the reliable connection to various trailers.

T110N

- Rated capacity:11000lbs
- Rated pulling capacity:1000N
- Travel speed(laden/unladen):4.3/7.5 mph
- Drive unit:2.6kW
- Standard 24V/465Ah lead acid battery
- Wheels' number 1x+2/2(x=driven wheels)



Well-designed and easy to maintain



Sideways battery exchange compartment plus adjustable handling bracket makes battery replacement easier and quicker.



Warning light makes driving safer.



Suspension castors from both side make the vehicle run more smoothly and safely.



The coasting button on both sides of the truck and emergency stop button allow the operator to operate truck forward/backward while walking beside. There is no need to get in and out of the truck frequently to operate it. At the same time, it reduces the speed while driving forward/backwards under coasting mode, making the traction safer and more efficient.

Display whole truck condition information via control instrument and multifunctional handle



German REMA multifunctional handle

Reliable and ergonomically designed Rema handle, each button can be easily reached and controlled, which makes driving more comfortable.



USB charging port

Double USB charging port power up more equipment.



The multifunctional control instrument can display truck conditions, battery capacity, working time, travel speed and steering angle. When something goes wrong, the outer ring light of the instrument will turn to red from green, and the fault code will be displayed.

pin code switch can set multiply start passwords, the ID card is also supported to start the truck.

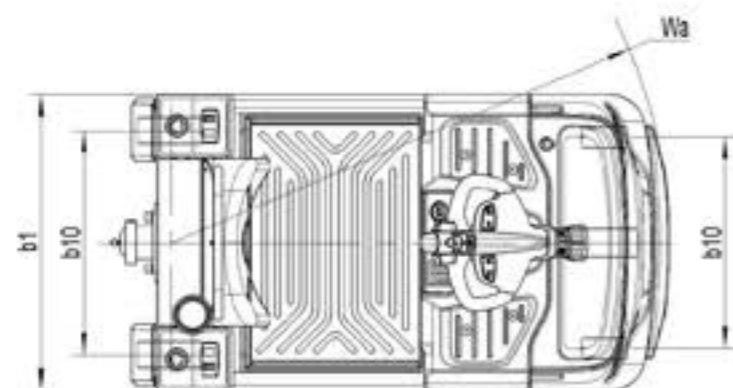
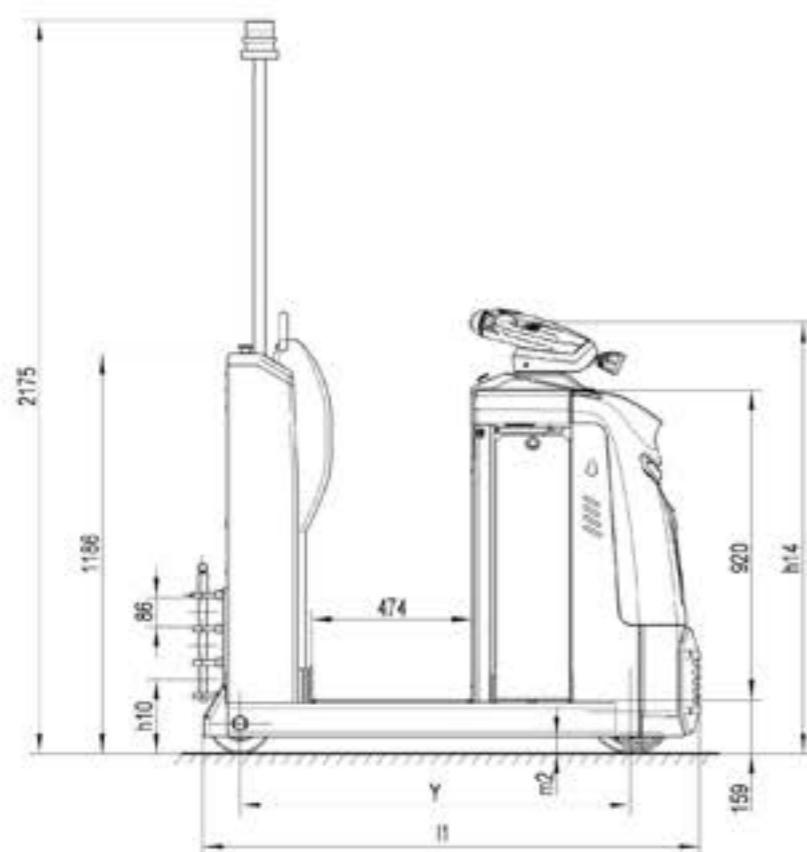

Type sheet for industrial truck acc.VDI2198

Distinguishing mark				
1.2	Manufacturer's type designation		T66N	T110N
1.3	Drive(Battery,Diesel oil,Petrol,Liquidified petroleum gas,electrical)		Battery	Battery
1.4	Operator type(Manual,Walking,Stand-on,Sit-on,Order picker)		Stand-on	Stand-on
1.5	Load capacity/Rated load	lbs	6600	11000
1.7	Rated pulling force	F(n)	800	1000
1.9	Wheelbase	y (in)	45.5	45.5
Weight				
2.1	Service weight(including battery)	lbs	2094	2249
2.3	Axle loading,unladen front/rear	lbs	1212/882	1345/904
Tires,chassis				
3.1	Tires(Rubber,High performance elastomer,Air,Polyurethane)		Solid rubber	Solid rubber
3.2	Tire size,front	Øxw (in)	Ø 9.1×2.8	Ø 9.8×3.1
3.3	Tire size,rear	Øxw (in)	Ø 7.1×3	Ø 7.1×3
3.4	Additional wheels(dimensions)	Øxw (in)	Ø 42.4×60	Ø 42.4×60
3.5	Wheels number front/rear(x-driven wheels)		1x+2/2	1x+2/2
3.6	Tread,front	b10 (in)	22.8	22.8
3.7	Tread,rear	b11 (in)	24.2	24.2
Dimensions				
4.9	Height of tiller in drive position min./max.	h14 (in)	50.4	50.4
4.12	Coupling height (hook center above ground)	h10 (in)	9.1/13/16.9	9.1/13/16.9
4.19	Overall length	l1 (in)	56.3 ¹⁾	56.3 ¹⁾
4.21	Overall width	b1 (in)	31.9	31.9
4.32	Ground clearance,centre of wheelbase	m2 (in)	2	2
4.35	Turning radius	Wa (m)	52.5 ²⁾	52.5 ²⁾
Performance data				
5.1	Travel speed,laden/unladen	mph	3.7 / 5.6	4.3 / 7.5
5.5	Pulling capacity,laden/unladen	N	800	1000
5.6	Max.pulling,laden/unladen	N	2000	3000
5.10	Service brake		Eletromagnetic	Eletromagnetic
Motor				
6.1	Drive motor rating	Hp	2.5	3.5
6.3	Battery acc to DIN43531/35/36A,B,C,nom		No	No
6.4	Battery voltage,nominal capacity K5	V / Ah	24/375	24/465
6.5	Battery weight	lbs	643.7	776
Additional data				
8.1	Type of drive control		AC speed control	AC speed control
8.4	Sound level at driver's ear acc to EN12053	dB(A)	<70	<70

1)Install crash pads l1=57.8in 2)Install crash pads Wa=53.5in;