

# NOBLELIFT

**ENTRY LEVEL  
STACKER  
2200 LBS**

**NEW**

## ADVANTAGES

- Ideal solution for low cycle applications.
- Built in charger for high autonomy.
- Battery discharge indicator with lift lock-out for improved battery life.
- 3-points design with centered drive for stability and traction.
- Mono-mast or wide space between masts for perfect view.

# PSE22M SL



Raising Expectations

**ESS LIFTS**



Elevating Efficiency

**EQUIPMENT**

**ESS LIFTS - AN AUTHORIZED DEALER**

[www.esslifts.com](http://www.esslifts.com)

# NOBLELIFT



## PSE22SL

▴ **Several masts options:**

Mono mast for 63" and 78" lift heights.

Duplex mast for 114", 128" and 138" lift heights.



▴ **Adjustable straddle leg**

Adjustable straddle leg design, suitable for diverse pallet sizes and more stability.

Low silhouette straddle design allows a lower bottom beam when accessing your rack which increases storage in the facility.



#### ▶ Built-in charger

The built-in charger allows charging anywhere in your work area, allowing higher efficiency for your work force.

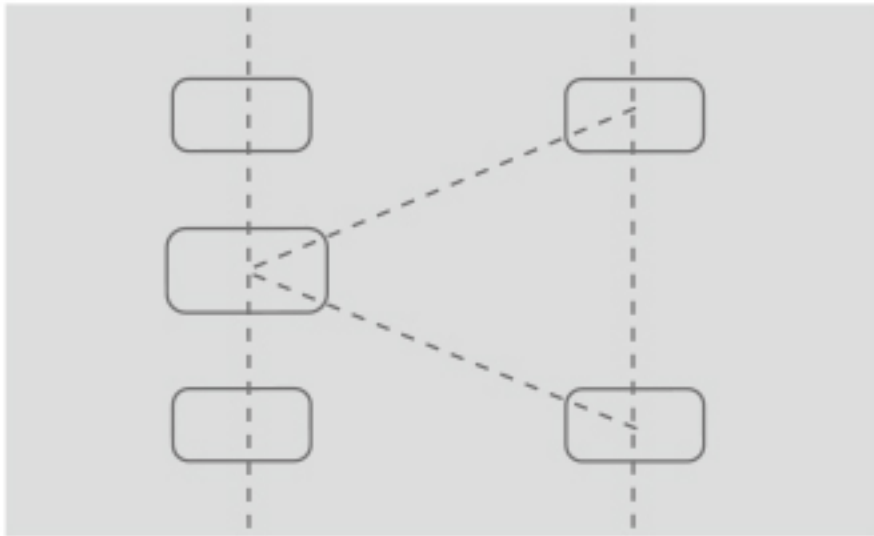

#### ▶ Stability

3-point design for improved traction with 2 stability casters for improved safety.



#### ▶ Robust profile

Interlocking, high tensile steel mast design for unlimited life and accurate lifting.



#### ▶ Powerful battery

2x12V 85Ah powerful maintenance free batteries (option 2x12V 106Ah).



#### ▶ Battery deep discharge protection

Lift lock-out improves the useful life of the battery. Tested and ergonomically designed emergency disconnect standard.

#### ▶ High Quality Components

All switches, sensors, and operating components are High quality, fully tested products.

#### ▶ Certification

Meets or exceeds EC standards as well as ISO 13849.

#### ▶ Applications

Ideal economic solution for all indoor low duty stacking operations.



#### ▶ Robust handle

Robust handle with steel housing and plastic coating ensures reliable and comfortable operation.

# PSE 22MSL

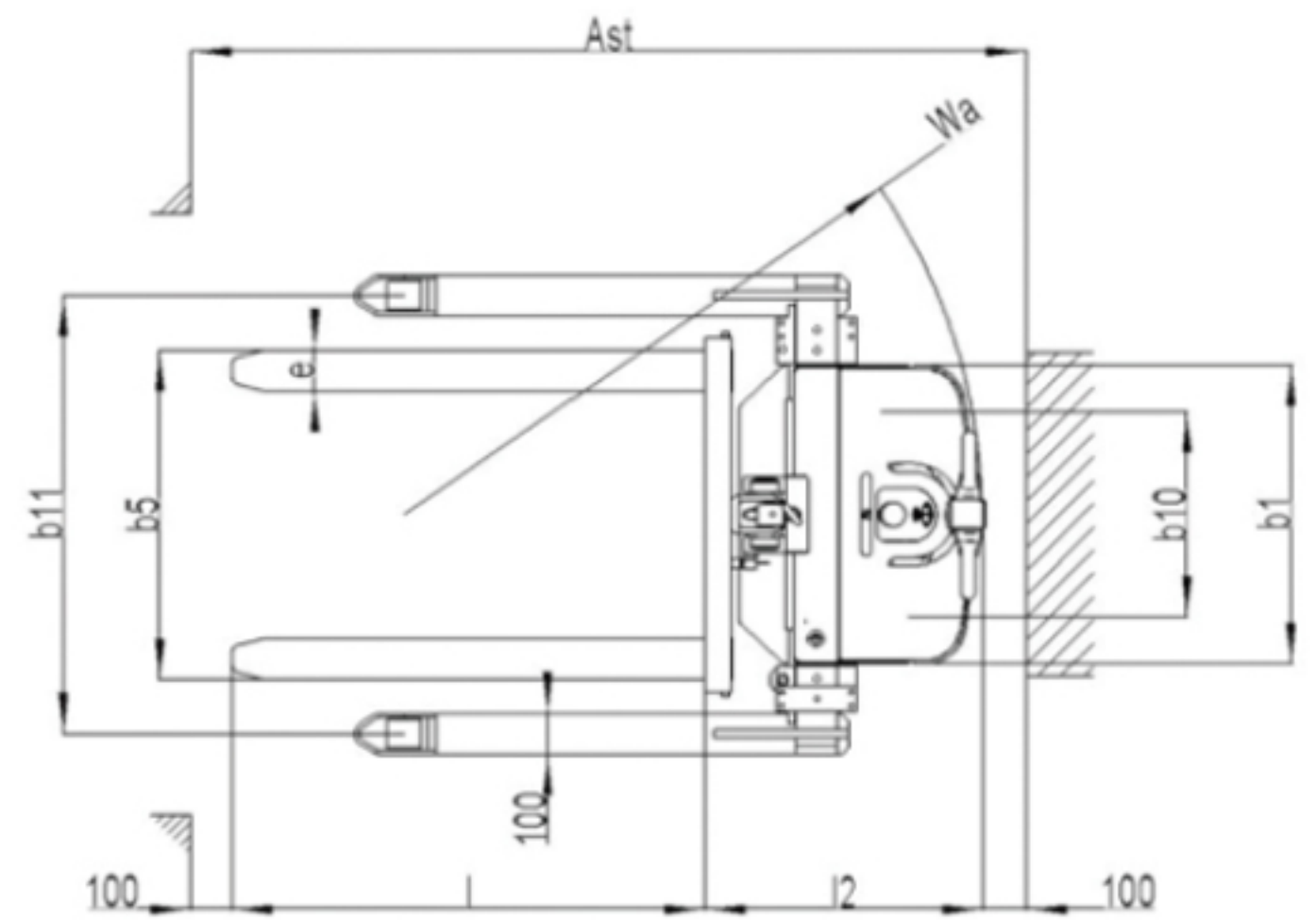
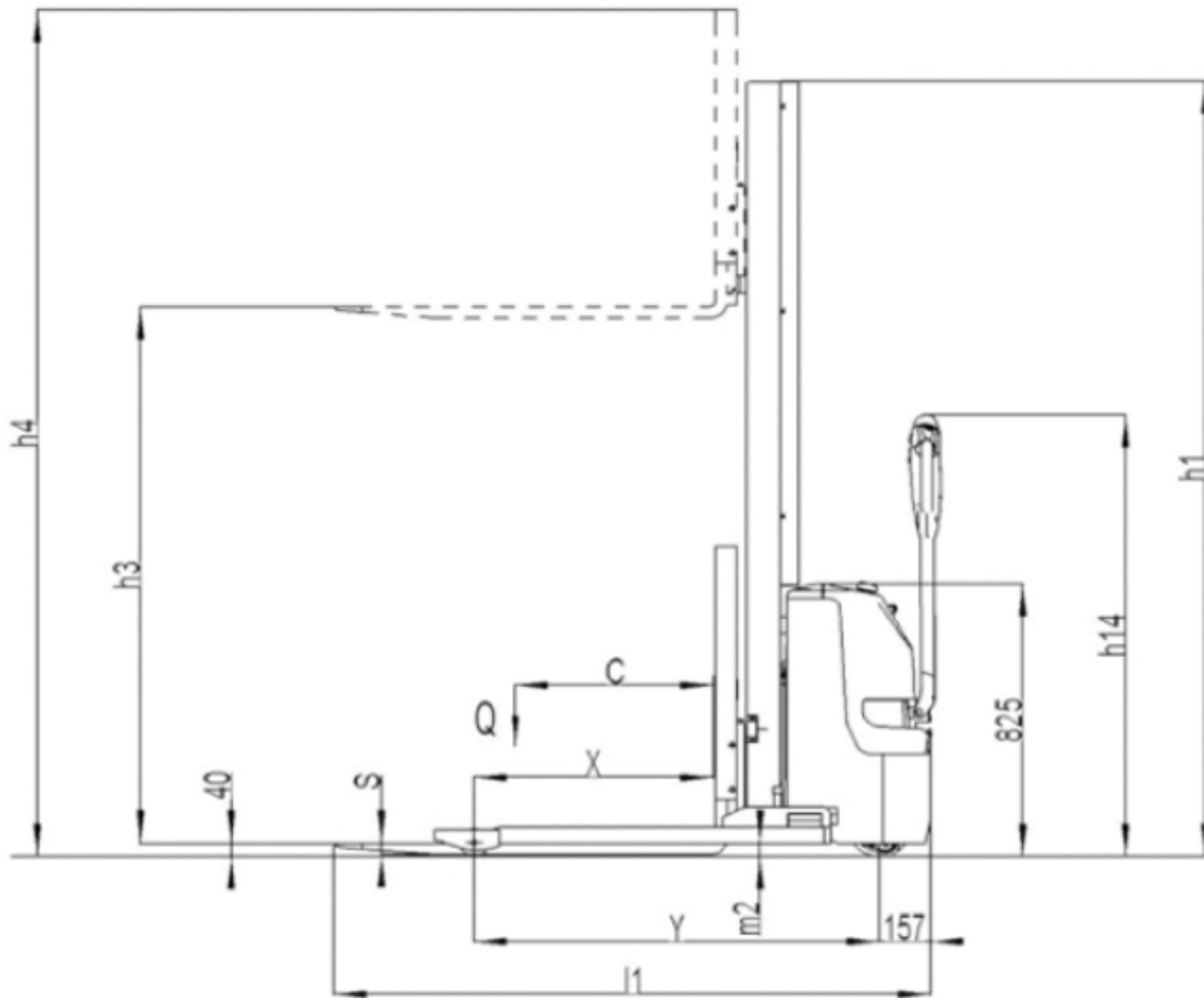

# PSE 22SL

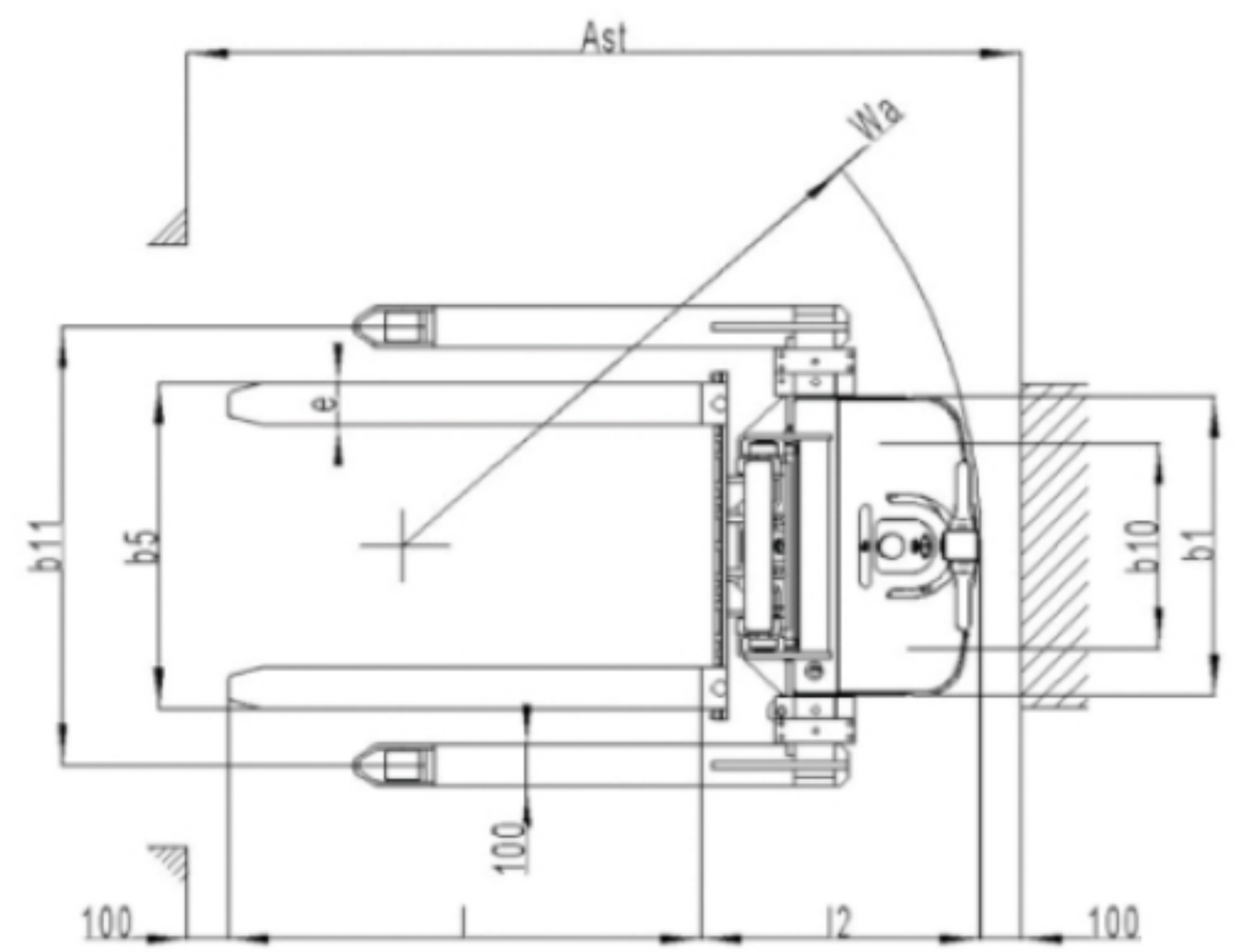
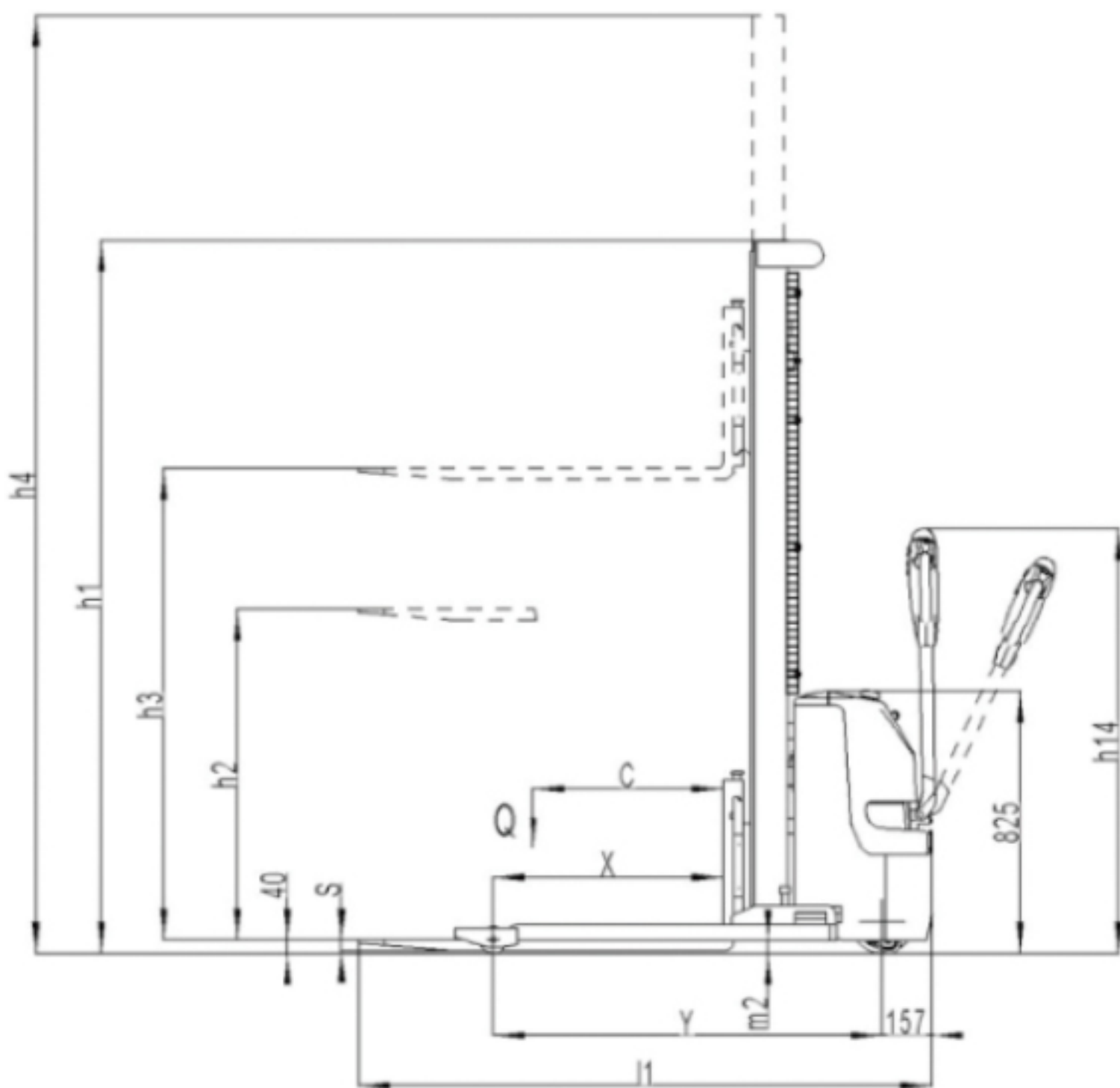

Type sheet for industrial truck acc. to VDI 2198

Distinguishing mark

1.2	Manufacturer`s type designation		PSE 22MSL(63)	PSE 22MSL(79)	PSE22SL(114)	PSE22SL(126)	PSE22SL(138)
1.3	Drive		Battery		Battery		
1.4	Operator type		Pedestrian		Pedestrian		
1.5	Load Capacity / rated load	Q (lbs)	2200		2200		
1.6	Load centre distance	C (in)	23.6		23.6		
1.8	Load distance, centre of drive axle to fork	X (in)	28.8		28.5		
1.9	Wheelbase	y (in)	48.3		48.3		

Weight

2.1	Service weight	lbs	1401.4	1430	1588.4	1621.4	1654.4
2.2	Axle loading, laden front/rear	lbs	1139.6/2444.2	1148.4/2464	1269.4/2503.6	1280.4/2525.6	1291.4/2547.6
2.3	Axle loading, unladen front/ rear	lbs	994.4/407	1014.2/415.8	1128.6/481.8	1150.6/470.8	1172.6/481.8

Tires, chassis

3.1	Tires		Polyurethane(PU)		Polyurethane(PU)		
3.2	Tire size, front	φx w (in)	Φ7.8×2.9		Φ7.8×2.9		
3.3	Tire size, rear	φx w (in)	Φ3.3×2.8		Φ3.3×2.8		
3.4	Additional wheels (dimensions)	φx w (in)	Φ3.1 × 1.2		Φ3.1 × 1.2		
3.5	Wheels, number front/ rear(x=driven wheels)		1x+2/2		1x+2/2		
3.6	Tread, front	b10 (in)	19.6		19.6		
3.7	Tread, rear	b11 (in)	42.1-53.9		42.1-53.9		

Dimensions

4.2	Lowered mast height	h1(in)	76.8	92.5	76.8	82.5	88.4
4.3	Free lift height	h2(in)	60.2	76		2.8	
4.4	Lift	h3(in)	60.2	76	111.8	123.6	135.4
4.5	Extended mast height	h4(in)	97.2	113	134.6	146.5	158.3
4.9	Height of tiller in drive position min. / max.	h14(in)	32.5/49.2		32.5/49.2		
4.15	Height, lowered	h13(in)	1.6		1.6		
4.19	Overall length	l1 (in)	71.3		71.3		
4.20	Length to face of forks	l2 (in)	26		26		
4.21	Overall width	b1 (in)	28.6		28.6		
4.22	Fork dimensions	s/e/l (in)	1.4/3.9/45.3		1.4/3.9/45.3		
4.25	Distance between fork-arms	b5 (in)	9.9-31.5		9.9-31.5		
4.32	Ground clearance, centre of wheelbase	m2 (in)	1.6		1.6		
4.33	Aisle width for pallets 1000X1200 crossways	Ast (in)	89.1		88.6		
4.34	Aisle width for pallets 800X1200 lengthways	Ast (in)	87.4		88.6		
4.35	Turning radius	Wa (in)	55.3		55.3		

Performance data

5.1	Travel speed, laden/ unladen	mph	2.3/2.5		2.3/2.5		
5.2	Lift speed, laden/ unladen	fpm	0.02/0.04		0.021/0.029		
5.3	Lowering speed, laden / unladen	fpm	0.03/0.04		0.02/0.02		
5.8	Max . gradeability , laden/unladen	%	5/10		5/10		
5.10	Service brake		Electromagnetic		Electromagnetic		

Electric-engine

6.1	Drive motor rating S2 60min	HP	0.6		0.6		
6.2	Lift motor rating at S3 7.5%	HP	2.95		2.95		
6.3	Battery acc. to DIN 43531 /35 / 36 A, B, C, no		no		no		
6.4	Battery voltage, nominal capacity K5	V/Ah	2×12/85		2×12/85		
6.5	Battery weight	lbs	2×55		2×55		
6.6	Energy consumption acc . to VDI cycle	kWh/h	0.65		0.62		

Additional data

8.1	Type of drive control		DC-Speed Controller		DC-Speed Controller		
8.4	Sound level at driver`s ear acc. to EN 12053	dB(A)	<70		<70		

# PSE22M SL PSE22SL

## Entry Level Stacker

### INTRODUCTION

The PSE 22 is an economic walkie-electric stacker, with rated capacity of 2200lbs and lifting height from 63inch to 137inch.

The compact and light design is suitable for a variety low duty applications in warehouses.



7719 Edison Ave  
Fontana, Ca 92336



info@esslifts.com



833-377-5438



www.esslifts.com

**AUTHORIZED DEALER**

**ESS LIFTS**

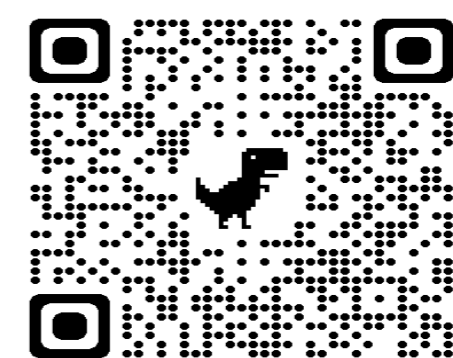

Official Website